



# Guidelines and Specifications

## for Residential Crossovers



Version 1.1, September 2017

**Contact:**

WALGA  
ONE70, LV 1, 170 Railway Parade West Leederville  
Phone: (08) 9213 2000  
Fax: (08) 9213 2077  
Email: [info@walga.asn.au](mailto:info@walga.asn.au)  
Website: [www.walga.asn.au](http://www.walga.asn.au)

**Acknowledgements:**

This guideline has been prepared by the Western Australian Local Government Association (WALGA) with the assistance of the Engineering Consultancy, Cardno

**DISCLAIMER**

To the extent permitted by law, WALGA exclude all warranties as to, and responsibility for, the accuracy, completeness or suitability of the information in this guideline or for any error or omission in the information and will not be liable for any loss or damage suffered or incurred by any persons arising from the use or reliance on the information or data contained in this guideline. To the extent permitted by law, WALGA disclaims all liability to the user for loss, injury or damage, arising out of, or related to, the use of the guidelines.

## Contents

<b>1.0</b>	<b>Glossary .....</b>	<b>1</b>
<b>2.0</b>	<b>Introduction.....</b>	<b>2</b>
2.1	Objective .....	2
2.2	Purpose.....	2
<b>3.0</b>	<b>Planning Guidelines .....</b>	<b>3</b>
3.1	Crossover Approval.....	3
3.2	Crossover Density .....	3
3.3	Crossover Location and Position .....	3
3.3.1	Prohibited Locations.....	3
3.3.2	Sightlines to Path Users .....	4
3.3.3	Distance to Obstructions .....	5
3.3.4	Sight Distance to Roadway Traffic.....	5
3.4	Paired Crossovers.....	7
3.5	Geometry .....	7
3.6	Assessment Criteria .....	7
<b>4.0</b>	<b>Design Guidelines .....</b>	<b>9</b>
4.1	Layout .....	9
4.1.1	Width.....	9
4.1.2	Length.....	9
4.1.3	Pedestrian Interface .....	10
4.1.4	Grades and Levels .....	10
4.2	Kerbing and Edging.....	11
4.2.1	Crossover Kerb Design .....	11
4.2.2	Edging.....	13
4.3	Block Pavement Structures .....	13
4.4	Existing Paths .....	14
4.5	Culverts.....	14
4.6	Redundant Crossovers.....	14
<b>5.0</b>	<b>References .....</b>	<b>15</b>

## APPENDIX A

<b>1.0</b>	<b>General</b> .....	<b>A-1</b>
1.1	Boundary Clearance.....	A-1
1.2	Street Furniture Clearance .....	A-1
<b>2.0</b>	<b>Schedule of Requirements</b> .....	<b>A-1</b>
<b>3.0</b>	<b>Construction</b> .....	<b>A-2</b>
3.1	Excavation .....	A-2
3.2	Concrete Crossover .....	A-3
3.3	Bitumen/Asphalt Crossover .....	A-4
3.4	Block Paved Crossover .....	A-5
3.5	Innovation in Construction Methods .....	A-6
3.6	Schedule of Requirements .....	A-6
<b>4.0</b>	<b>Contractor Responsibilities</b> .....	<b>A-7</b>
<b>5.0</b>	<b>Typical Drawings</b> .....	<b>A-8</b>

## 1.0 Glossary

Name	Definition / Commentary
<i>Alignment of Path</i>	The location of the path within the verge area
<i>Battle-axe lots</i>	A block of land behind another, with access from the street via a separate crossover
<i>Block pavement structure</i>	Block patterns which are generally used in the construction of driveways
<i>Clearance</i>	The space required between the path and an obstruction
<i>Crossfall</i>	Grade across the path width; necessary for adequate drainage
<i>Crossover</i>	A constructed crossing giving access from a public thoroughfare to private land or a private thoroughfare serving the land.
<i>Crossover splay/wings</i>	The flared edges of a driveway
<i>Culvert</i>	A tunnel carrying an open drain under a road
<i>Edge Restraint</i>	A support constructed at the edge of a driveway to improve longevity
<i>Gates</i>	Vertical elements to control access to the path
<i>Grade</i>	The slope of a path or driveway
<i>Gutter</i>	Edge of road where it meets the kerb
<i>Hazards</i>	Any object or situation that constitutes a risk to users
<i>Kerb</i>	Roadway edge treatment
<i>Narrow lots</i>	Describes lots with a frontage width of <12m
<i>Obstructions</i>	An object that constitutes an obstacle to crossover/path users
<i>Paired crossovers</i>	Combined crossovers which service more than one property and located adjacent to one another
<i>Shared Path</i>	A pathway that is specifically intended to be used by both pedestrians and bike riders. Note that all paths may be used by cyclists and pedestrians.
<i>Side-entry pits</i>	A stormwater pit located adjacent to the kerb and designed to collect stormwater from the road surface
<i>Sightlines</i>	The visual envelope of vehicles and path users
<i>Standards and Policies</i>	Applicable guidelines for use in Western Australia
<i>Stopping sight distance</i>	The distance a vehicle driver needs to be able to see in order have room to stop before colliding with something in the roadway
<i>Street Lights</i>	A light which illuminates surrounding roads and footpaths, usually mounted on a tall post.
<i>Street Trees</i>	Trees located within the verge area
<i>Utility boxes</i>	An enclosure which houses utility services for electrical, communications, etc
<i>Vegetation</i>	Soft landscaping element

## 2.0 Introduction

### 2.1 Objective

To provide property owners, builders and designers with the information required to ensure that cross overs meet the requirements of the <City/Shire/town>.

### 2.2 Purpose

This document comprises guidelines for planning and design of residential crossovers, including an example construction specification in Appendix A. When adopted by Local Government it provides a consistent framework to assist builders and their contractors to understand and meet the requirements of the Local Government.

This Guideline provides for crossover design that references statutory and best-practice guidance documentation which includes the following:

- *Austrroads Guide to Road Design*
- *Australian Standards AS2890.1:Off-street parking (2004)*
- *State Planning Policy 3.1 - Residential Design Codes (R-Codes)*
- *WAPC Liveable Neighbourhoods*

The Guideline is most applicable in greenfield residential developments, where lot layout and access configuration can be controlled to a higher degree, however the principles remain valid for brownfield residential development.

## 3.0 Planning Guidelines

### 3.1 Crossover Approval

In accordance to *Schedule 9.1, Clause 7 of the Local Government Act 1995 and Regulation 12, 13 and 15 of the Local Government (Uniform Local Provisions) Regulations 1996*, an application to the Local Government must be made by the landowners to request approval to construct a crossover.

### 3.2 Crossover Density

The principle for designing crossovers in Western Australia is to design for the least amount of crossovers in a given area where possible (*R-Codes*). This improves the safety of path users and lowers costs associated with constructing and maintaining crossovers. Minimising the number of crossovers also reduces the level of conflict and friction along busier roadways, and creates additional space for street trees, pedestrian crossing and on-street parking.

The *R-Codes* specify a maximum density of 1 crossover per 20m of frontage, where housing density is greater than R40. A single crossover per property is to be provided where required for housing density less than R40. Narrow lots should be constructed with paired crossovers to minimise conflict and retain verge space for street trees, lighting, overhead power and on-street parking.

All residential lots are entitled to access irrespective of the constraints of location (AS2890.1: Clause 3.2.3a).

### 3.3 Crossover Location and Position

Crossover location shall be determined and crossovers designed to address the following issues and criteria:

#### 3.3.1 Prohibited Locations

Australian Standards (*AS2890.1: Figure 3.1*) sets out exclusion zones for access driveways related to the proximity of adjacent intersections (see **Figure 1** below). This exclusion zone may be increased if necessary for signalised intersections to ensure that the driveway is not within the influence of traffic queues. This requirement does not apply to any access driveway serving a property which would otherwise be denied access due to the physical impossibility of meeting the requirement. Additional restrictions are placed on non-domestic driveways and should be discussed with Local Government.

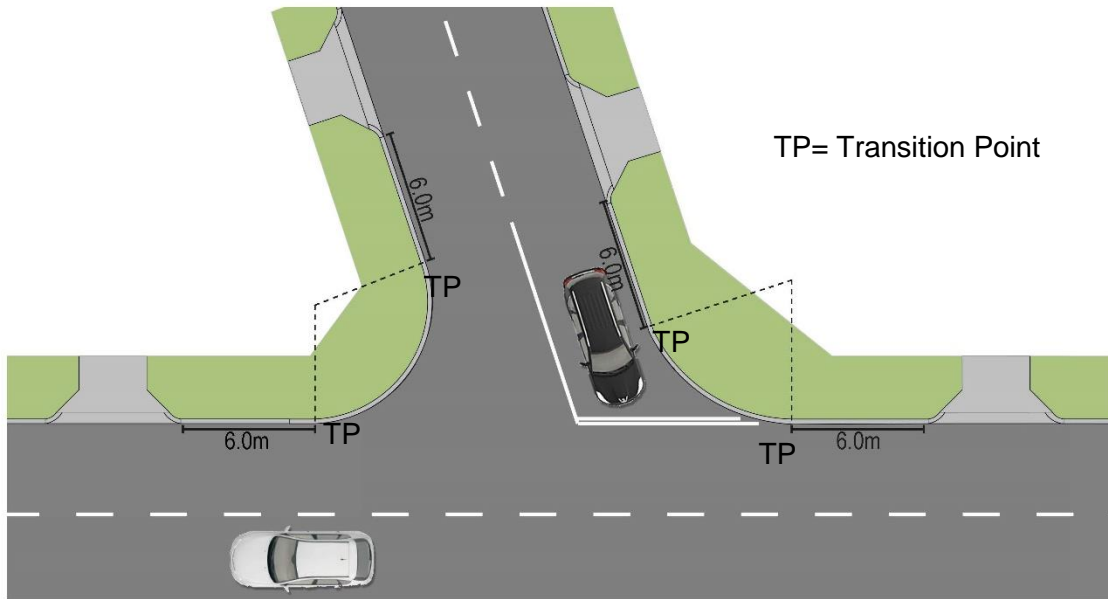

Figure 1 Permitted Locations for Crossovers

### 3.3.2 Sightlines to Path Users

Crossovers are to be positioned such that sight lines between path users (pedestrians and cyclists) and vehicles are unobstructed by permanent fixtures (fences, trees, etc).

*AS2890.1: Figure 3.3* (see Figure 2 below) defines a sight triangle of 2.0m x 2.5m at the intersection of the driveway and path edge, within which walls, fences and other structures are to be truncated or reduced to no higher than 0.75m (R-Codes 6.2.3 C3). Fencing to apply with *Dividing Fences Act, Local Laws and Local Planning Policies*.

Where path infrastructure is located further from the lot boundary truncations may be reduced, to a minimum of 1.5mx1.5m, maintaining sightlines as described above.



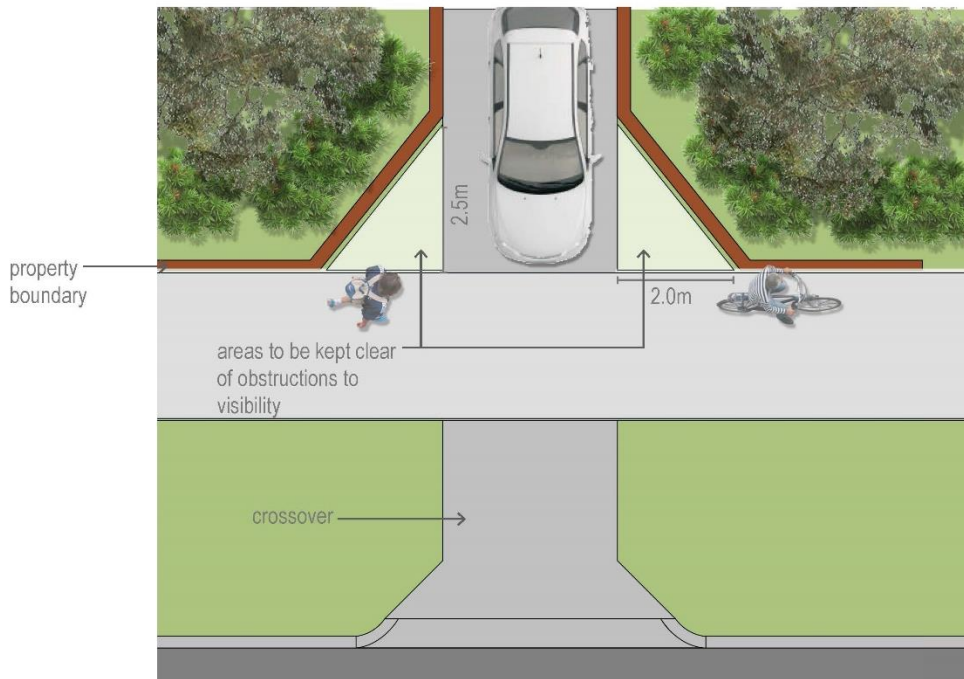

Figure 2 Minimum Pedestrian Sightlines

### 3.3.3 Distance to Obstructions

All elements of the crossovers shall be located at a minimum distance to obstructions (including wings/radii) as follows:

- Side-entry pits: 1.0m
- Street trees: 2.0m
- Utility boxes: 1.0m
- Street lights/Power poles: 1.0m (as required by Western Power's *Guidelines for Placement of Power Poles within Road Reserves in Built-Up Areas, 2006*)
- Bus stops: 1.0m
- Bus shelters: 1.5m
- Pram ramps: 1.0m

If crossovers must be constructed within this distance, the obstruction shall be relocated wherever possible. In special cases (e.g. development at brownfield sites, narrow battle-axe driveways and/or paired crossovers) where relocation of obstructions is not feasible, justification should be provided to the Local Government and a decision to be made on a case by case basis.

### 3.3.4 Sight Distance to Roadway Traffic

The requirements for minimum sight distance at the road interface are defined by Australian Standards (*AS2890.1: Figure 3.2*), see **Figure 3** below.

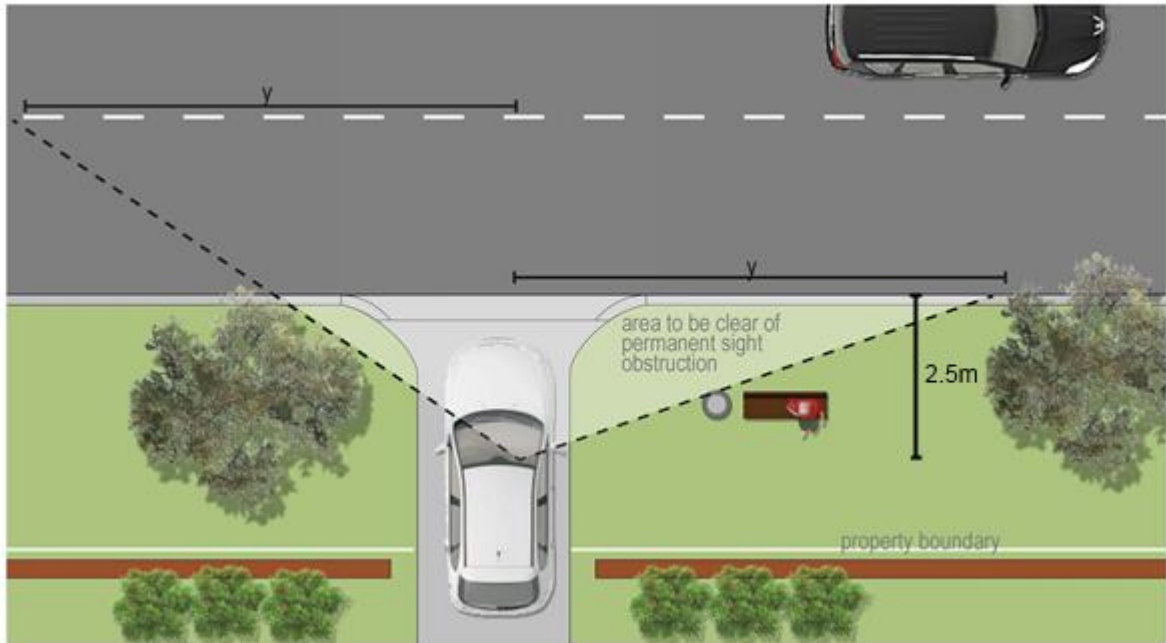

**Figure 3 Sight Distance Calculation Geometry**

The distance Y is determined according to the prevailing speed along the adjoining roadway, chosen as the greater of posted speed limit or observed 85<sup>th</sup> percentile speed, shown in **Figure 4** (adapted from AS 2890.1: Figure 3.2).

Frontage Road Speed (km/hr)	Domestic Property Absolute Minimum (m)	Minimum SSD (m)
40	30	55
50	40	69
60	55	83
70	70	97
80	95	111
90	125	130
100	139	160
110	153	190

**Figure 4 Minimum Sight Distance Requirements**

Wherever practical, a domestic property access shall satisfy the Desirable 5 Second Gap or Minimum SSD (Stopping Sight Distance) values defined above.

To ensure adequate sight distance, all visually impermeable walls, fences, vegetation and other obstructions shall be maintained no higher than 0.75m within the identified area. Note that fencing standards are determined by Local Governments and additional requirements may apply.

### 3.4 Paired Crossovers

Paired crossovers are recommended for narrow lots. Where residential properties are located along a Neighbourhood Connector streets with between 5,000 to 7,000 vehicles per day, vehicles must be able to exit in forward gear, however, if this cannot be achieved then paired driveways with the ability to reverse into a parking lane are recommended (*R-Codes and Liveable Neighbourhoods*). An example of paired crossovers is shown in **Figure 5**.

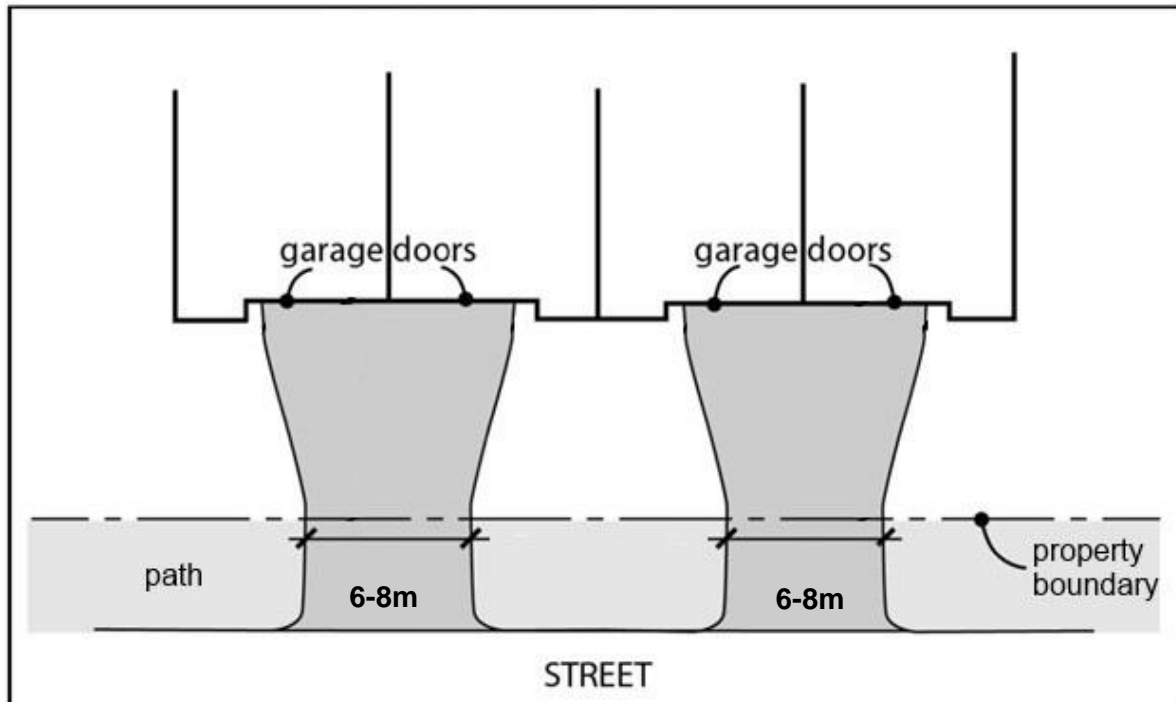

Figure 5 Example of Paired Crossovers (adapted from Seattle Municipal Code)

### 3.5 Geometry

Crossovers shall be aligned at right angles to the street alignment, wherever possible (*R-Codes*).

### 3.6 Assessment Criteria

A list of criteria for crossover designs are provided below:

- Crossovers shall be adequately paved and drained in accordance with Local Government requirements
- The visual and physical continuity of the footpath is to be maintained (or reinstated) through the crossover
- Crossovers shall provide unobstructed vehicle access to the individual lots and motorists must be able to enter or reverse from the lot in a single movement. (For roads with more than 5,000 vpd, all vehicles must be able to exit in forward gear).
- If the frontage road is two-way and has more than two lanes and there is a provision for right turns either into or out from the crossover, then additional consultation with Local Government is required. Many Local Governments have policies and restrictions governing the provision of crossover along multilane roads and can be based on various factors such as road hierarchy, traffic volumes, traffic speeds or road function.

An example of a good design is shown in the **Figure 6** which illustrates consistent crossover design with priority pedestrian access.



**Figure 6** Example of Design Showing Path Priority

## 4.0 Design Guidelines

### 4.1 Layout

#### 4.1.1 Width

Sufficient width and an adequate splay or 'wing' configuration must be provided for the safe turning movement of vehicles both from and onto the carriageway.

The requirements of AS2890.1 have precedence with respect to minimum design requirements and are replicated as follows for residential crossovers under the following classification:

- User Class 1A: Residential domestic and employee parking (*AS2890.1: Table 1.1*)
- Access facility Category 1: <25 bays (*AS2890.1: Table 3.1*)

Crossover width is defined in the above documents as follows:

- A minimum of 3.0m for all developments
- A maximum of 3.0m for lots with a frontage of 12.5m or less, except where the R-Codes allow the construction of a double garage, in which case a maximum width of 4.5m applies
- A maximum width of 6.0m for lots with a frontage in excess of 12.5m.

Main Roads defines a minimum driveway radius of 1.5m (*Main Roads WA: Urban Driveway Setout – Light Vehicles Drawing No. 200431-0198-1*).

Many Local Government Guidelines allow for apron widening 'wings' rather than radii at the road boundary. The purpose of the wings of residential crossovers is to provide for ease of entry and exit by vehicles.

Comparison of 'wing' dimensions across a variety of WA Local Governments suggests an appropriate standard width is 1.5m, consistent with the general intent of Main Roads WA recommendations. In special circumstances where the standard wing width cannot be achieved, an absolute minimum of 1.0m may be adopted.

Where paired driveways are provided, the minimum combined driveway width shall be 6m (*Liveable Neighbourhoods 2009: Element 2 - Clause R51*). The maximum combined driveway width shall be 8m, excluding apron widening 'wings'.

In regards to battle-axe developments; for a single battle-axe lot, the minimum driveway width is 3.0m whereas for adjoining battle-axe lots, the combined driveway width shall be 6m.

#### 4.1.2 Length

Sufficient storage length must be provided (crossover and/or driveway length) for a vehicle to stand clear of the roadway. Where the entrance has a gate, the set back from the road edge to the gate shall be a minimum of 6m to allow for this (*Main Roads Driveways Design Guide*). Physical limitation such as verge depth will affect this value. A length less than 6m requires justification and is subject to the Local Government's approval

### 4.1.3 Pedestrian Interface

Crossovers are defined to be 'Road-Related Areas' under the *Road Traffic Code 2000*. Pedestrians and cyclists in these areas have priority over vehicles. For this reason it will be recommended that the pedestrian infrastructure be provided in a continuous manner across all residential driveways, maintaining path crossfall and material in preference to the crossover construction. Therefore, the ultimate crossover must be designed to match path levels, where applicable.

The following design standard for grades and levels is considered in the context of this path position, which represents the most constrained option for crossover construction, as shown below in **Figure 7**.



Figure 7 Plan View of Model Crossover Design

### 4.1.4 Grades and Levels

- Path construction guidelines dictate a maximum crossfall of 2.5% to cater for people who have a disability (*Austroads Guide to Road Design 6A, Clause 5.6*). To allow the path to shed water and to avoid ponding, a crossfall of 2.0-2.5% is recommended.
- The maximum longitudinal gradient of a crossover at the property boundary is defined by Australian Standards to be 5% (*AS2890.1:2004, Clause 2.6.2 and Clause 3.3a*). This allows safe Disability Access from the path to the property boundary.
- As a reference guide, Main Roads advises that at a point 1.5m into a crossover there shall be a vertical rise of at least 100mm from the gutter (*Main Roads, Driveway D12#57413*), and this is an acceptable minimum standard to apply to all residential crossovers. This height is achieved using either of the kerb types described in **Section 4.2**.
- The maximum gradient of a crossover is defined in Section 2.2.1.2 in *IPWEA's Subdivision Guidelines* is 1 in 8 (12.5%)

- In areas of steep grades, the *IPWEA Subdivision Guidelines Section 3.3.4: Verge and property grades* states that the verge on the high side may be graded at 2.0% for three metres and then battered to suit the finished contours at a maximum of 16%.
- *Austrroads' Guide to Road Design - Part 6A: Pedestrian and Cyclist Paths* recommend that shared paths (i.e. paths intended to be used by both cyclists and pedestrians) be an absolute minimum of 2.0m and a desirable minimum of 2.5m in width. They should be located at least 500mm, and preferably 1.0m from any significant obstruction or hazard, including the roadway, to provide sufficient separation and safety. This guidance, shown in **Figure 8**, constrains the design envelope for residential crossovers, as discussed further in **Section 4.2**.



**Figure 8 Typical Longitudinal Driveway and Verge Section Design**

\*A 2.5m width may not be achievable or desirable in all cases

In the absence of a pedestrian path, the maximum grade for a crossover should be 5%. This will allow pedestrian footpaths to be retrofitted if desired without significant modifications to the existing geometry.

## 4.2 Kerbing and Edging

Existing semi-mountable and barrier kerbing shall be removed from the crossover location, and replaced by the crossover kerb defined below, **Figure 9**. The extent of kerb to be cut should be identified and confirmed with Local Government, then cut with a concrete saw and removed without damage to road pavement.

### 4.2.1 Crossover Kerb Design

To provide smooth transition from the road edge to the crossover and particularly to the pedestrian path in the most highly constrained situation, the kerb profile must provide 155-160mm vertical rise from the gutter, over a 500mm distance.

To achieve the required height at 500mm, it is recommended that a standard IPWEA (*IPWEA Subdivision Guidelines Figure 3.2: Kerbing Profiles*) mountable kerb profile is installed and in-situ concrete poured to fill the gap (200mm) at a slope to achieve the

desirable vertical rise of between 155 – 160mm above the gutter. Alternatively, a Crossover Kerb profile can be used to improve constructability. Standard dimensions of these kerb types are shown in **Figure 9**.

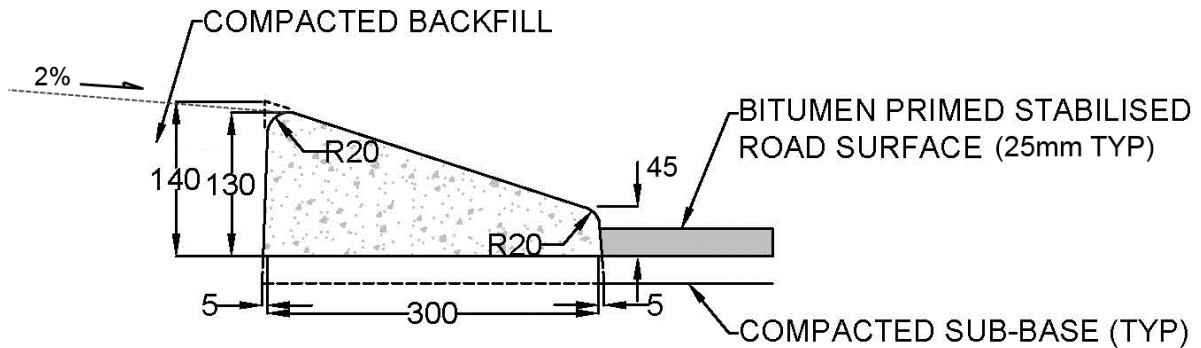

**Standard IPWEA Mountable Kerbing**

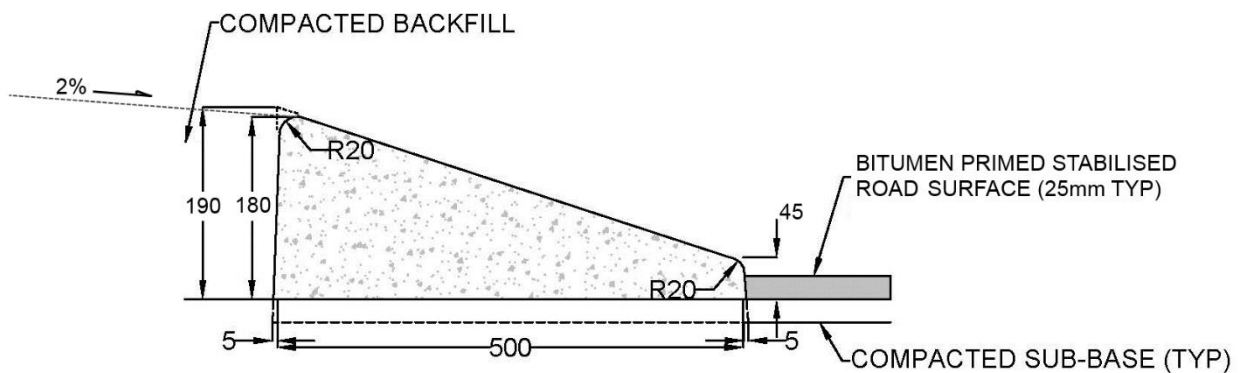

**Alternative Crossover Kerb**

**Figure 9 Typical Kerb Geometry**

The use of keyed kerbing is recommended on sweeping bends and may be a requirement of Local Government.

**Figure 10** provides an example of best practice alignment and construction of crossover kerbs.





Figure 10 Crossover Kerb Example

### 4.2.2 Edging

A restraining edge is required for Bitumen/Asphalt and Block paving residential crossovers, as follows:

Rigid block or concrete edging is to be provided at the perimeter of all block paved crossovers to prevent lateral movement of the header course.

Restraints shall be robust enough to withstand vehicle impact and prevent the lateral movement of the paving blocks. Edge restraints shall be installed to the same level as the crossover.

### 4.3 Block Pavement Structures

Comparison of block paver specifications across a variety of Western Australian Local Governments suggests an appropriate minimum thickness shall be 60mm.

Applicable block paving patterns for driveway crossover are stretcher bond and 45 or 90 degree herringbone pattern as shown in **Figure 11**. The most preferred pattern is 45 or 90 degree herringbone because the pattern tightly interlocks the bricks and it can handle significant weight, which is ideal for driveways. Rectangular stretcher bond are generally not advised as the structural integrity is inferior to other patterns.

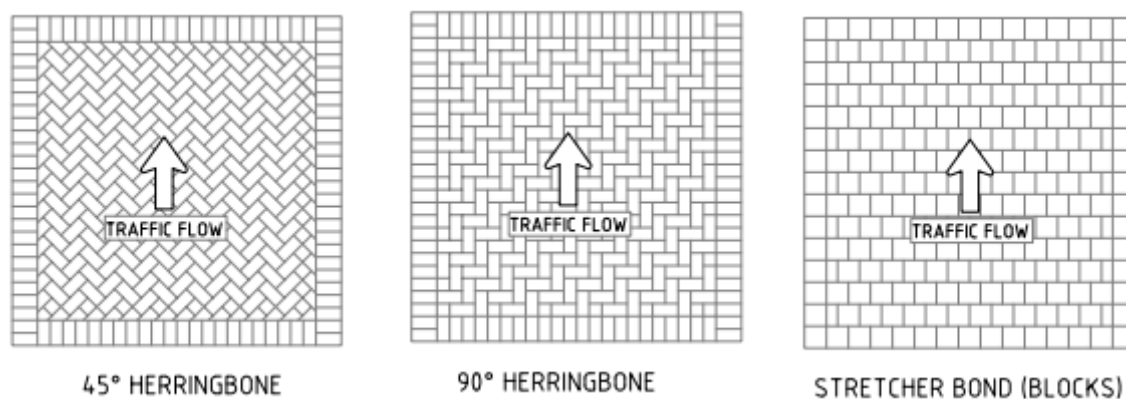

Figure 11 Residential Block Paving Patterns

## 4.4 Existing Paths

The path shall be kept in a safe condition at all times, with appropriate signage and traffic management implemented in accordance with Traffic Management for Works on Roads Code of Practice (Main Roads WA) , warning pedestrians of construction works until reinstatement work is completed.

Where the existing footpath or shared path is in-situ concrete, in good condition and is over 100mm thick, then the footpath can be preserved. The crossing shall be constructed both sides of the concrete path and matched up with it (see **Section 3: Planning Guidelines**).

Existing shared paths are exempt from the conditions in *Clause 4.1.3: Pedestrian Interface* to prevent the removal of good quality paths.

The existing path shall only be removed and replaced if it falls under any of the following conditions:

- Is damaged or less than 100mm thick for residential crossovers;
- Is not in-situ concrete;
- Has an incorrect gradient.

Paths identified for removal are to be assessed beforehand by the Local Government or approved contractor.

## 4.5 Culverts

Where a residential crossover traverses an open drain or swale, a culvert will be required. This situation is common in regional and rural developments, with design highly dependent on the local environment. Refer to Local Government Specifications for culvert design.

## 4.6 Redundant Crossovers

Any redundant crossovers shall be removed and the verge, kerbing and footpath (if present) reinstated to fit in with the surrounding form/development pattern.

## 5.0 References

*Austrroads Guide to Road Design - Part 3: Geometric Design*

*Austrroads Guide to Road Design - Part 6A: Pedestrian and Cyclist Paths*

*Australian Standards AS 2890.1:Off-street parking (2004)*

*Australian Standard AS 1428.1: Design for access and mobility*

*Guidelines for Placement of Power Poles within Road Reserves in Built-Up Areas (Western Power, 2006)*

*IPWEA Local Government Guidelines for Subdivisional Development*

*Local Government Act 1995*

*Local Government (Uniform Local Provisions) Regulations 1996*

*Main Roads WA Driveways Design Guide*

*Main Roads WA Standard Drawings for Driveways*

*Main Roads WA: Urban Driveway Setout – Light Vehicles Drawing No. 200431-0198-1*

*Road Traffic Code 2000 (WA)*

*State Planning Policy 3.1 - Residential Design Codes (R-Codes)*

*WAPC Liveable Neighbourhoods*

# APPENDIX A

## Construction Specifications and Typical Drawings for Residential Crossovers

### 1.0 General

#### 1.1 Boundary Clearance

- a) Minimum 0.5m from the side property line (as per R-Codes - including battle-axe driveways servicing a subdivided block).
- b) Minimum 6.0m from the corner truncation peg.

#### 1.2 Street Furniture Clearance

- a) Side-entry pits – 1.0m.
- b) Street trees – 2.0m.
- c) Utility boxes – 1.0m.
- d) Street lights/Power Poles – 1.0m.
- e) Bus stops – 1.0m.
- f) Bus shelters – 1.5m.
- g) Pram ramps – 1.0m.

Where physical limitations may prevent attaining these minimum clearances, consultation with Local Government is required.

### 2.0 Schedule of Requirements

- a) **Minimum width at property boundary – 3m**
- b) **Maximum width at property boundary –**
  - 3m for lots with a frontage of 12.5m or less (except for the construction of a double garage, in which case a maximum of 4.5m applies).
  - 6m for lots with a frontage in excess of 12.5m.
- c) **Minimum width for paired crossover at property boundary – 6m.**
- d) **Maximum width for paired crossover at property boundary – 8m.**
- e) **Depth –**
  - Concrete: 100mm minimum.

- Bitumen/asphalt: 25mm minimum (Note that some Local Governments prohibit the use of bitumen/asphalt).
  - Block paving: paver depth to be 60mm minimum
- f) **Radii/Wings** – The width of ‘wings’ on the apron at kerb line shall be minimum 1.5m. If kerb radii is used instead of wings, the radius shall be 1.5m. In special cases where the standard wing width cannot be achieved, an absolute minimum of 1.0m may be adopted.
- g) **Gradient and Levels** –
- Maximum crossover gradient over paths is 2.5%
  - At the property boundary, the maximum longitudinal gradient is 5%.
  - In areas of steep grade – the verge on the high side may be graded at 2.0% for three metres and then battered to suit the finished contours at a maximum of 16%.
- h) **Levels** – Contact the Local Government for the required crossover levels. At a distance of 1.5m into a driveway there must be a vertical height of at least 100mm from the invert of the kerb. As a general guide, the crossover shall match up with:
- The existing verge level if it is of uniform height with the adjacent verges.
  - The average level of the two adjacent crossovers or verge levels where there are no crossovers.
- To maintain drainage, the back of the crossover apron (i.e. ramp section) should be maintained at the level of the top of kerb or the existing verge level, whichever is highest.
- i) Crossovers shall not be constructed closer than 6m, measured from the crossover splay, to the intersection of property lines at street corners as per AS 2890.1, wherever practicable. For crossovers located near traffic lights, Main Roads Western Australia guidelines and standards apply. Additional restrictions are placed on non-domestic driveways and should be discussed with Local Government.
- j) Crossovers shall be constructed at right angles (90 degrees) to the street alignment, wherever practicable.
- k) Crossovers shall provide a non-slip surface finish.

## 3.0 Construction

### 3.1 Excavation

Excavation for the crossover shall be taken to the levels, lines and grades as set by the Local Government. The decision to retain, remove or alter existing pathways, kerbs or any other affected infrastructure shall be to the approval of the Local Government. All excavations shall be executed cleanly and efficiently to provide for a consolidated sound base free of depressions, soft spots or any deleterious materials.

- a) The contractors shall be responsible for ensuring that all excavated material is removed from the site at the same time as the excavation is carried out. No excavated material shall be stockpiled on site or buried in the verge.
- b) Existing barrier or semi-mountable type kerbing is to be cut with a concrete saw and removed without damage to road pavement, remaining kerbing or services. To facilitate

neat removal and subsequent reinstatement, the concrete or bitumen to be removed shall be completely separated from the adjoining concrete or bitumen by means of a concrete or bitumen saw.

- c) When an existing concrete path has thickness of 100mm or more, in good condition, and adjacent to the lot boundary or kerb line, the crossing shall be constructed either side of the concrete path, as approved by the Local Government.

The existing path shall be removed and replaced where it is damaged, is less than 100mm thick or has an incorrect gradient. Crossovers should never take precedence over the path (AS1428.1).

- d) An existing asphalt path shall be reconstructed if it is damaged, is less than the nominal thickness, has an incorrect gradient, and/or where the path has not been reinforced.
- e) The subgrade shall be watered, thoroughly compacted and shaped to provide a dense uniform surface to the approval of the Local Government. If the subgrade comprises substandard material, for example clay or gravels that cannot be adequately compacted to provide sufficient support, then the material must be replaced or treated at the direction of the Local Government.

### 3.2 Concrete Crossover

- a) **Subgrade** – Subgrade suitability and compaction compliance to be in accordance with Local Government direction. The subgrade shall be compacted to a minimum of 95% Maximum Dry Density (MMDD).
- b) **Concrete** – All concrete used shall develop compressive strength of 25 MPa at 28 days. The concrete to be used shall be composed of a mixture of sand, cement, aggregate and water to give strength specified with a maximum slump of 80mm. Concrete and its placement shall conform to AS 1379 (1991) and AS 3600 (1988) respectively.
- c) **Reinforcement** – Steel reinforcement may be required in the construction of concrete crossovers, for higher levels of projected traffic and load. Consult with the Local Government.
- d) **Placing concrete** – The base shall be thoroughly and evenly moistened, but not saturated, prior to placing concrete. All stones or other deleterious materials shall be removed from the base prior to pouring concrete. Concrete shall be evenly placed to the depth specified and shovelled into position continuously and spaded, especially at all edges, to give maximum density. No concrete shall extend on the road surface. No break in operation shall be permitted from time of placing concrete to finishing.
- e) **Kerbing** – To be in accordance with the Typical Drawings, kerb profile details. Concrete strength to be a minimum of 25 MPa @ 28 days.
- f) **Finishing** – Surface finish shall be obtained by screeding to the correct levels and finished with a transverse brooming tool to provide a non-slip dense surface, free of any depressions, float marks, irregularities, honeycomb sections or slurry likely to cause excessive surface wear. Edges shall be smoothed using a 100mm wide edging tool.
- g) **Jointing** – Expansion joints shall be full depth joints and filled with bitumen-impregnated canite or similar approved material and butyl mastic sealer. Expansion joints should be located at:
- i. The lot boundary and both sides of a path where there is a path and also at the back of the kerb section adjoining the crossing.

- ii. Where it adjoins a rigid structure or any public utility structure.
- iii. The ends of the existing kerbing where kerbing has been removed.
- iv. 6m maximum spacing on long crossings.

Contraction joints shall be made with an approved jointing tool with 2m maximum spacing either laterally or longitudinally.

### 3.3 Bitumen/Asphalt Crossover

*Note:* Bitumen/Asphalt Crossovers may be prohibited by some Local Governments.

- a) **Subgrade.** Subgrade suitability and compaction control shall be at the direction of Local Government. The subgrade shall be compacted to a minimum of 95% MMDD
- b) **Base Material** – Basecourse material shall be in compliance with the *WALGA Specification 1 – Granular Pavement Materials (Type 1.2, 2.2 or 3.2)* or at the direction of Local Government.
- c) **Basecourse**– Basecourse is to have a total consolidated thickness of not less than 100mm for residential crossovers. The thickness shall be increased to 150mm if limestone is used as the basecourse material. Material to be spread, rolled, water-bound and corrected as necessary to shape, grade, etc. The thickness shall be increased to 150mm if the asphalt is to be paver laid. The basecourse shall be compacted to 98% MMDD.
- d) **Asphalt** – Black asphalt shall be type RAC10 with 50 Marshall Blow, red asphalt shall be type AC10 Laterite with 50 Marshall Blow in accordance with IPWEA/AAPA specification for supply and installation of asphalt road surfacing. The compacted thickness of the asphalt shall be 25mm for a crushed stone or granular basecourse and 40mm for a limestone basecourse.
- e) **Laying** – Asphalt work should not be done in cold, windy or wet conditions as thin layers of asphalt (30mm or less) cool rapidly in these situations and will not be compacted adequately. The finishing work shall be undertaken while the material is hot, to produce a fine, dense, smooth surface, free of surface voids.
- f) **Edging** – The edges of the crossover are to be formed using a flexible 30mm deep steel border pegged to shape (to be removed on completion), to provide a symmetrical and uniform shape and appearance. A gravel shoulder, 500mm wide and 100mm thick, should be provided at the edges of the crossover to finish flush with the top of the asphalt surface. Concrete kerb laid to finish flush with the final surface of the crossover may also be used as edge restraints.
- g) **Kerbing** – To be in accordance with the Typical Drawings, kerb profile details. Concrete strength to be a minimum of 25 MPa @ 28 days.
- h) **Surface** – The surface is to be again reshaped and base course added where required to give correct shape. The surface is to be well watered and rolled with a vibrating roller, slurried and swept clean of any loose material.

### 3.4 Block Paved Crossover

- a) **Subgrade** - Subgrade suitability and compaction control shall be at the direction of Local Government. The subgrade shall be compacted to a minimum of 95% MMDD.
- b) **Base Material** – Base course material shall be in compliance with the *WALGA Specification 1 – Granular Pavement Materials (Type 1.2, 2.2 or 3.2)* or at the direction of Local Government.
- c) **Basecourse** – Basecourse is to have a total consolidated thickness of not less than 100mm for residential crossover. Material to be spread, rolled, water-bound and corrected as necessary to shape, grade, etc. The thickness shall be increased to 150mm if limestone is used as a basecourse material.
- d) **Compaction** – The base course shall be compacted to 98% MMDD. The subgrade shall be compacted to a minimum of 95% MMDD. Compaction control shall be at the direction of Local Government.

The block pavement should be compacted and brought to level by not less than three passes of the vibrating plate compactor. Plywood of 12mm thickness shall be used either attached to the base of the compactor or laid on the blocks as a cushion to prevent damage to the surface.
- e) **Bedding layer** – The bedding layer shall have a final compacted thickness of 25mm ± 5mm. The bedding layer shall be well-graded concreting sand, free of deleterious soluble salts and other contaminants, complying with Concrete Masonry Association, PA02, Concrete Segmental Pavements. The sand should be of uniform moisture content, and is to be spread over the compacted base course and screeded in a loose condition.
- f) **Paving Blocks** – The paving units shall be either clay or concrete, 60-76mm thick complying with AS4455 and AS4456.
- g) **Laying** – The paving units shall be laid onto the loose bedding sand with a gap of approximately 2-3mm between adjacent bricks. Part bricks shall be neatly cut to size with hydraulic guillotine, bolster or saw.
- h) **Joint filling** – The sand used for joint filling should be finer than the bedding layer and comply with Concrete Masonry Association, PA02, Concrete Segmental Pavements. As soon as possible after compaction, dry sand for joint filling shall be broomed over the pavement and into the joints. Excess sand shall be removed as soon as the joints are filled.
- i) **Edge restraint** – Edge restraint shall be provided to withstand vehicle impact and prevent lateral movement of the paving bricks. Edge restraint can be provided by placing at least 100mm wide (preferably 250mm wide) and 100mm deep minimum cast in-situ concrete strip or precast concrete kerb along both sides of the crossover. The use of sand/cement mortar is not recommended as an edge restraint.
- j) **Kerbing** – To be in accordance with the Typical Drawings, kerb profile details. Concrete strength to be a minimum of 25 MPa @ 28 days.



### 3.5 Innovation in Construction Methods

The above recommendations do not preclude the application of innovative construction methods, such as permeable pavements or recycled materials. However, any such departures from standard design methods should be discussed with Local Government through the crossover application process.

Recycled road base manufactured from crushed demolition materials can be used as both base and subbase. The material must be in accordance with the *IPWEA/WALGA Specification for the Supply of Recycled Road Base*.

### 3.6 Schedule of Requirements

**Table 1-1 Schedule of Requirements**

<b>Schedule of Requirements</b>	
<b>CONCRETE</b>	
<b>Item</b>	<b>Residential</b>
Thickness	100mm
Concrete Strength Capacity @ 28 days	25 MPa / 80mm slump
<b>BLOCK PAVED</b>	
<b>Item</b>	<b>Residential</b>
Thickness of Blocks	60 mm min
Sand Bedding	25mm ± 5mm
Basecourse (crushed stone or gravel)	100mm
OR	
Basecourse - Limestone	150mm
<b>ASPHALT</b>	
<b>Item</b>	<b>Residential</b>
Asphalt	25mm
Basecourse (crushed stone or gravel)	100mm
OR	
Asphalt	40mm
Basecourse - Limestone	150mm

*Note:* Specified thicknesses assume adequate subgrade support. If weak subgrades are present then alternative pavement design measures will be required at the direction of the Local Government.

## 4.0 Contractor Responsibilities

- a) The identification, location and protection of all services.
- b) Cut existing barrier kerbing with a concrete saw and remove without damage to pavement or remaining kerbing or services.
- c) Ensuring that a permit for the concrete works has been issued by the Local Government.
- d) Remove and dispose of all surplus material from the site and leaving the site in a clean and tidy condition at all times.
- e) Remove all formwork without damage to concrete or pavement or existing kerbing.
- f) Reinstatement of kerbing, concrete or brick paving or bituminous road surfaces to comply with Local Government specifications if damaged during the course of the works.
- g) The repair of any damage to Public Utility Service or any other thing damaged during the course of works. May require approval from Local Government or service provider prior to repair.
- h) The protection of private property from damage and the new crossover surfaces from the rain damage or vandalism.
- i) Liaison with the ratepayer to provide for access and egress and notification of intention to commence works.
- j) Maintain good public relations with the Local Government and ratepayers.
- k) Cutting of all bitumen where removal is specified.
- l) To pay all fees charged by Waste Disposal Sites in respect of excavated material.
- m) Traffic management and the safety of vehicles and pedestrians affected by the works
- n) Notification and compliance with all the requirements of the relevant local government or road authority including inspections to be completed.
- o) The construction of a standard crossover may be eligible for Local Government contribution. The amount contributed is at the discretion of the governing Local Government.

## 5.0 Typical Drawings

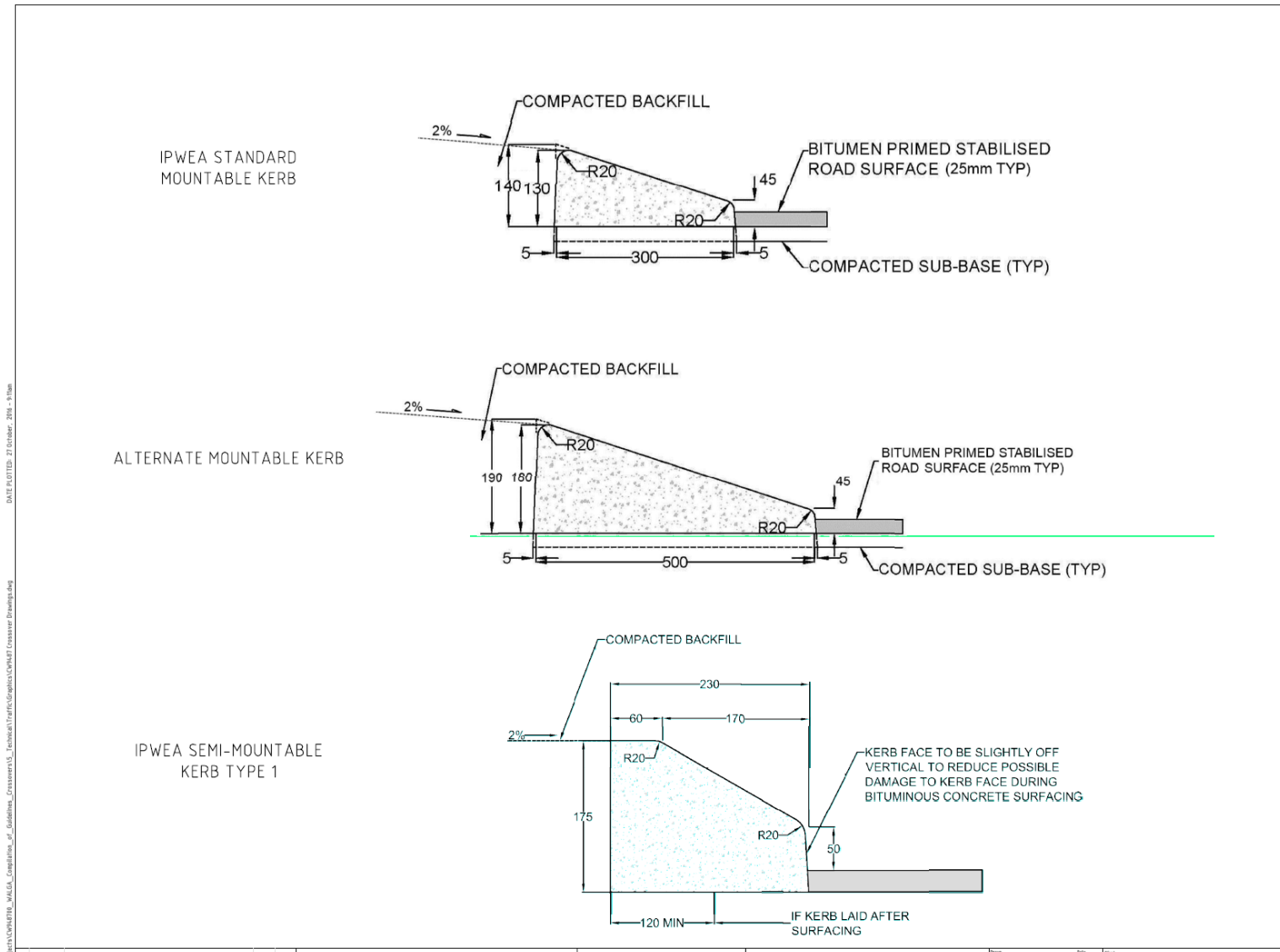

GENERAL NOTES:

TECHNICAL NOTES:

DATE PLOTTED: 27 October, 2014 - 9:10am  
 CADD FILE: \\projects\ip\project\CADD\IPR\_WALGA\_Compilation\_of\_Guidelines\_Crossover\15\_Traffic\Traffic\Guidelines\CIPMKT\_Crossover\_Drawing.dwg

Rev	Date	Description	Drawn	Appr

© Caradco Limited. All Rights Reserved.  
 This document is produced by Caradco Limited on behalf of the client in accordance with the terms of the contract. Caradco Limited does not and shall not accept any responsibility or liability whatsoever to any third party arising out of any use or reliance on this document.

  
 Caradco  
 11 Harcourt Terrace, P.O. Box 442,  
 West Perth, Western Australia 6150  
 Phone 081 9213 3888  
 Fax 081 9213 3846

  
 WALGA  
 08/78, LYN, 178 Millway Parade,  
 West Leederville, WA 6007  
 PO Box 624, West Perth WA 6150  
 Tel: 081 9213 3100  
 Fax: 081 9213 3271

Drawn	Date	Class
Checked	Date	Project
Approved	Date	Title
		KERB PROFILE DETAILS

Drawn	Checked	Scale	Date
Drawing Number	Revision	Scale	Revision

0 10 20 30 40 50 60 70 80 90 100 110 120 130 140 150 160 170 180 190 200 ON A1 ORIGINAL

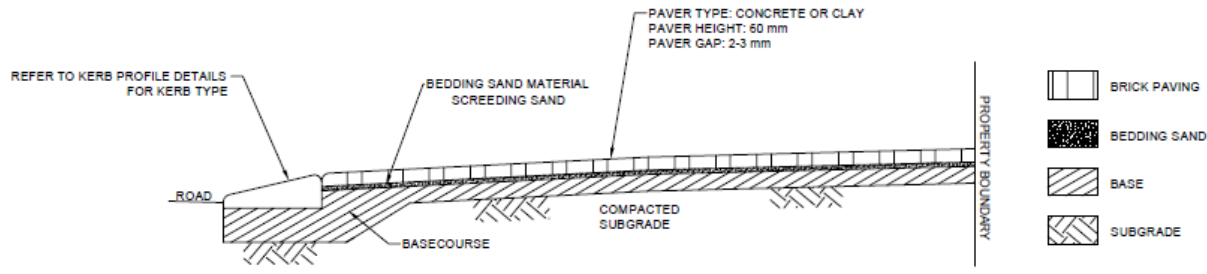

BRICK PAVED CROSSOVER SECTION

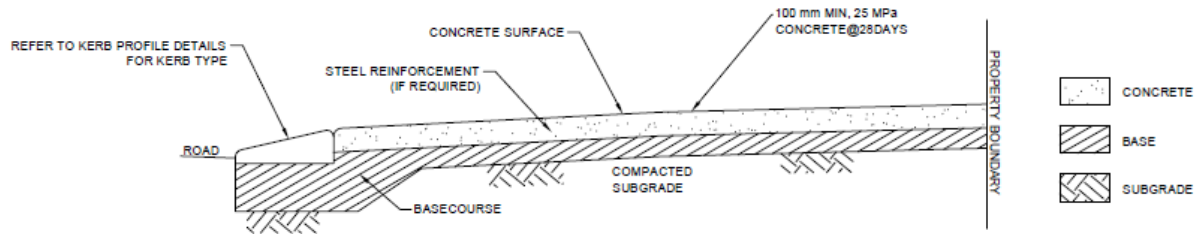

CONCRETE CROSSOVER SECTION

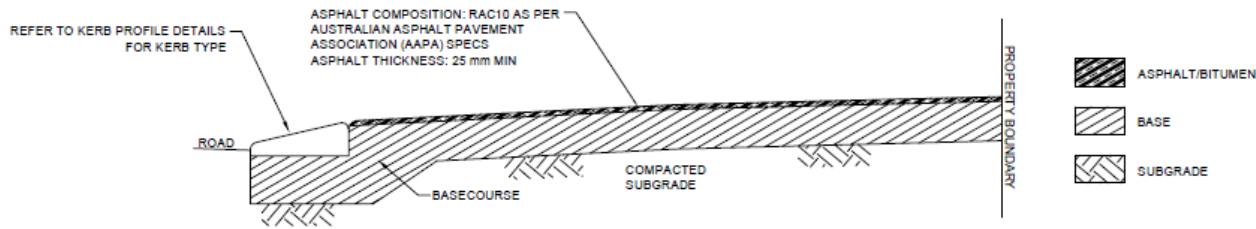

ASPHALT/BITUMEN CROSSOVER SECTION

**GENERAL NOTES:**

- SURFACES SHALL BE TREATED TO PROVIDE A NON-SLIP SURFACE.

**TECHNICAL NOTES:**

SCHEDULE OF REQUIREMENTS	
BRICK PAVED	
THICKNESS	60 - 75MM
SEND BEDDING	30MM
BASE - ROCK BASE/GRAVEL	100MM
OR	
SUB BASE - LIMESTONE	150MM
CONCRETE	
THICKNESS	100MM
STEEL REINFORCEMENT	5MM BARS X 200MM SQUARES
CONCRETE STRENGTH CAPACITY @ 28 DAYS	25 MPa / 90MM SLUM
ASPHALT	
BASE COURSE	100MM; 25MM ASPHALT
OR	
SUB BASE - LIMESTONE	150MM; 40MM ASPHALT

Rev	Date	Description	Drawn	Appr

© Caradco Limited All Rights Reserved.  
 This document is prepared by Caradco Limited solely for the  
 client and is not to be used for any other purpose without the  
 written consent of Caradco Limited. Caradco Limited does not  
 assume any responsibility or liability whatsoever for any loss  
 or damage arising out of any use or reliance on this drawing or the  
 content of this document.



Caradco Pty Ltd  
 15/1601 Terrace, P.O. Box 447,  
 West Perth Western Australia 6009  
 Phone 08 9375 1888  
 Fax 08 9375 1888



WALGA  
 36/276 LVL 1/19 Kingsway Parade,  
 West Leederville, WA 6007  
 P.O. Box 514, West Perth WA 6009  
 Tel: 08 923 2800  
 Fax: 08 923 2877

Drawn	Check	Rev	Date	By	Date	Project	Title

**CONSTRUCTION MATERIAL SPECIFICATIONS**

Material	Specs	Notes	Drawn	Check



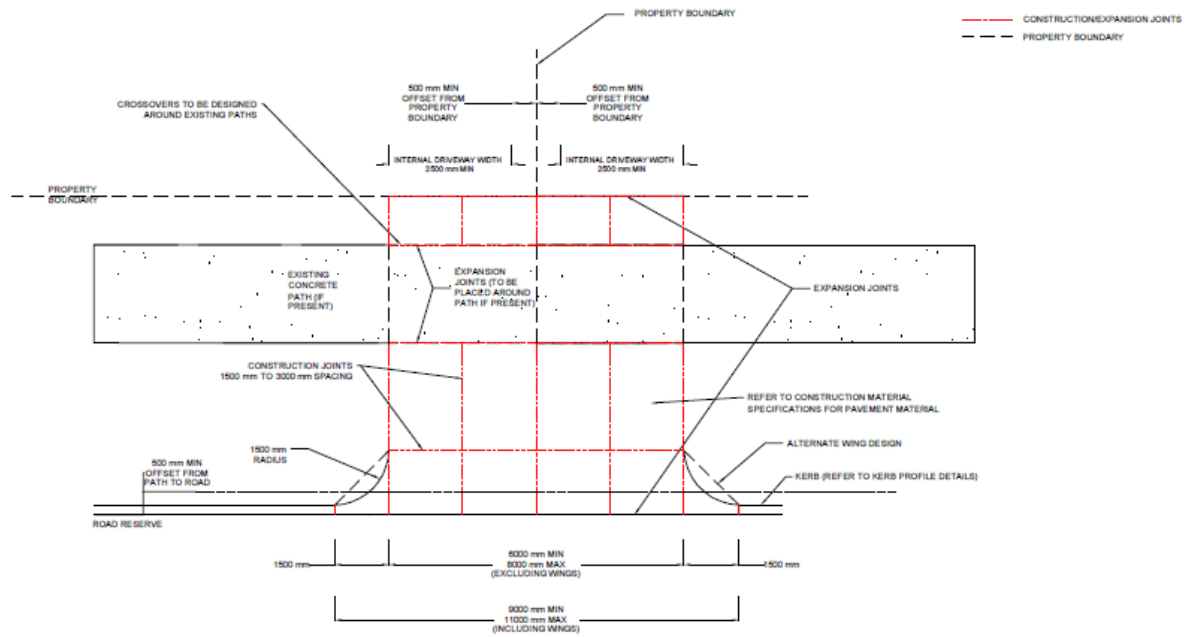

PAIRED CROSSOVER - PLAN LAYOUT

GENERAL NOTES:

1. RED LINES - CONSTRUCTION/EXPANSION JOINTS
2. REFER TO AS 2890.1 FIGURE 3.1 FOR CROSSOVER LOCATION AND POSITIONING.
3. REFER TO AS 2890.1 FIGURE 3.3 FOR PEDESTRIAN SIGHTLINES
4. CROSSOVERS SHOULD BE LOCATED AT MINIMUM DISTANCE TO OBSTRUCTIONS AS FOLLOWS:
  - 4.1. SIDE-ENTRY PITS: 1.0M
  - 4.2. STREET TREES: 2.0M
  - 4.3. UTILITY BOXES: 1.0M
  - 4.4. STREET LIGHTS/POWER POLES: 1.0
  - 4.5. BUS STOPS: 1.0M
  - 4.6. BUS SHELTERS: 1.5M
  - 4.7. PRAM RAMP: 1.0M

TECHNICAL NOTES:

Rev	Date	Description	Drawn	Appr

© Carbro Limited All Rights Reserved.  
 This document is prepared by Carbro Limited solely for the  
 use of the client and is not to be used for any other purpose  
 or in any other way. Carbro Limited does not accept any  
 liability for any loss or damage of any kind arising from  
 the use of this document.



Issue	Date	Drawn

RESIDENTIAL PAIRED CROSSOVER TEMPLATE			



## WALGA

ONE70, LV 1, 170 Railway Parade West Leederville

PO Box 1544, West Perth, WA 6872

Phone: (08) 9213 2000

Fax: (08) 9213 2077

Email: [info@walga.asn.au](mailto:info@walga.asn.au)

Website: [www.walga.asn.au](http://www.walga.asn.au)